

# VERTICAL LIFTING CLAMP (Lock lever type)



Vertical lifting clamp for the lifting of steel plates and steel structures.



Equipped with Remote control and releasing mechanisms

## FEATURES

- The spring-loaded tightening lock mechanism assures a positive initial clamping force.
- With the use of a remote control lever and rope, which are supplied with the clamp, the clamp can be unlocked from the floor to detach from the work piece.
- The clamping force increases in proportion to the weight of the load.
- The main body and the shackle are made of die-forged special alloy steels, which are optimally tempered for maximum strength and durability.
- High-frequency quenching of die-forged special alloy steels gives greater durability to the cam.
- The main body is a baked-on finish.

## SPECIFICATIONS

Item No.	Rated capacity (ton)	Jaw opening (mm)	N.W. (kg)
SVC 0.5L	0.5	0~19	3
SVC 1L	1	0~25	6
SVC 2L	2	0~30	10.5
SVC 3L	3	0~35	12.5
SVC 5L	5	0~40	21.5

## TIGHTENING LOCK MECHANISM

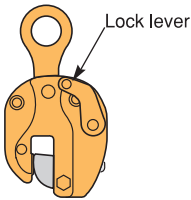

(Tightening)

- The clamp will lock onto the work piece when the lock lever is pulled completely upwards as shown in the drawing.
- When locked, the shock from the work piece coming to rest on the floor or the slackening of the sling rope will not cause the clamp to come lose from the work piece.

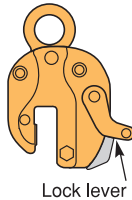

(Releasing)

- The clamp will unlock and the cam will retreat into the body when the lock handle is pulled completely downwards as shown in the drawing.
- When the clamp is high out of reach, the clamp can be unlocked via the remote control unlocking lever and rope.

## EXAMPLES OF USE

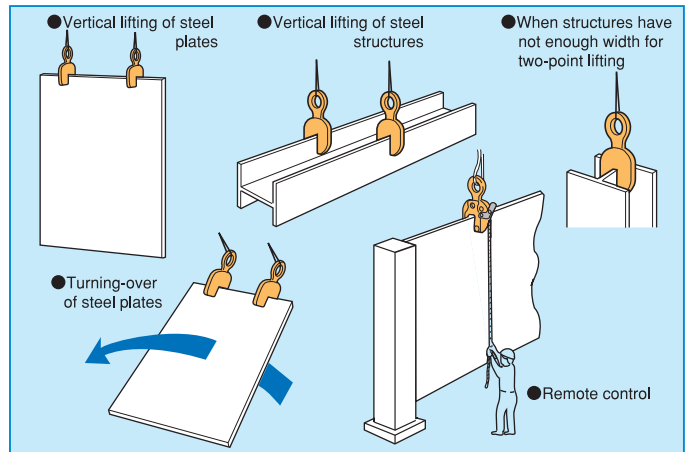

Always lift work pieces at 2 or more points for safety.

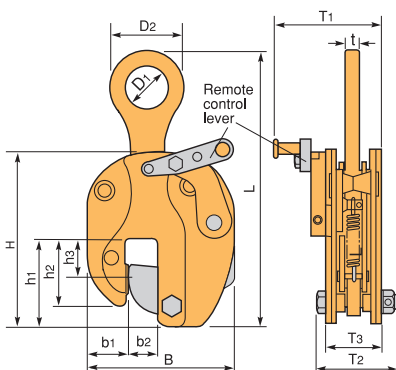

## DIMENSIONS TABLE

Item No.	L (MAX)	H	h1	h2	h3	B	b1	b2	D1	D2	T1	T2	T3	t
SVC 0.5L	250	158	80	60	36	131	36	26	36	64	89(80)	67	49	12
SVC 1L	310	185	90	69	45	151	42	32	48	85	113(104)	81	59	16
SVC 2L	375	210	100	77	47	172	48	39	60	106	130(118)	97	71	18
SVC 3L	405	225	105	81	47	182	51	42	66	117	141(129)	102	75	20
SVC 5L	455	260	120	95	49	220	65	50	84	148	157(145)	122	92	22

※ When the remote control unlocking levers are not installed, refer to the values in the above table for T1 shown in parenthesis.  
 ※ The main bodies of SVC-5L is made of high-tensile steel plates.